

Olie/Benzine afscheider in PE

- Met coalescentiecel
- Slibafscheider
- Automatische afsluiter
- Teruglozing < 5 mg/l

EN858-1

HSKPEA30

Behandelingseenheid voor regenwater
Totale behandeling

Behandeld debiet l/s	L mm	P mm	E mm	S mm	Dn mm	Fe mm	H mm	D mm	Gewicht kg
30	4000	1640	1280	1250	200	590	1840	630	687

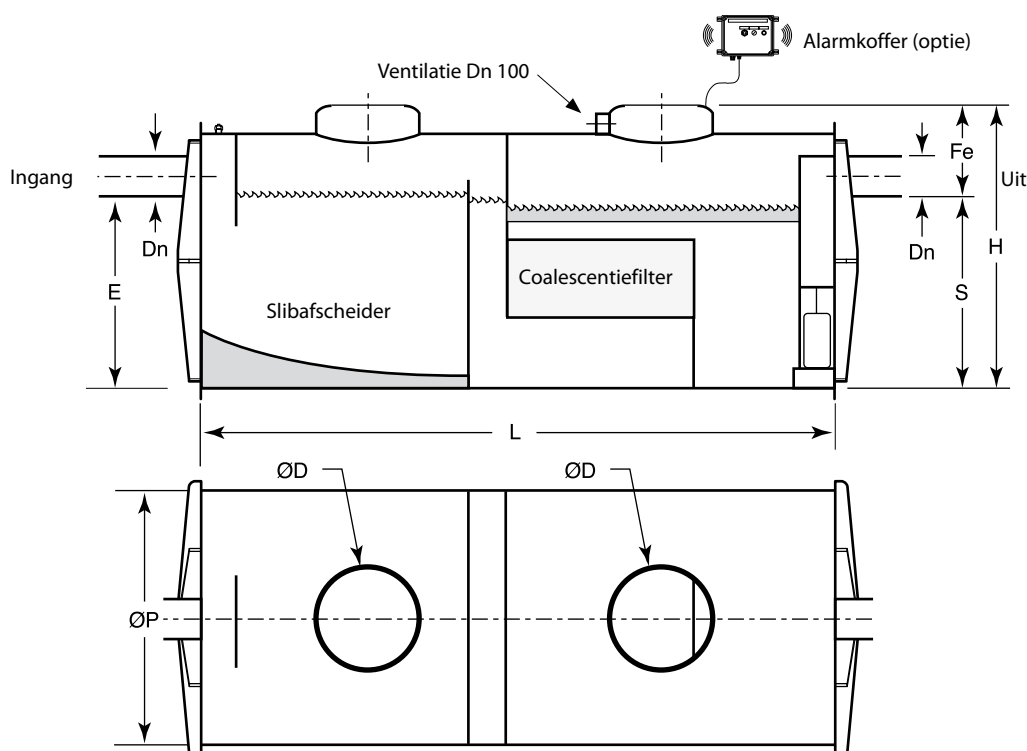

Hydraulische kenmerken

- Totaal nuttig volume _____ 5700 l
- Nuttig volume slibafscheider _____ 3000 l
- Nuttig volume afscheider _____ 2700 l
- Stockage koolwaterstoffen _____ 1596 l
- Afscheidingsrendement _____ 99,9 %
- Afscheidingsoppervlakte _____ 16,62 m²
- Afscheidingscoefficient _____ 0,554 m²/l/s
- Hydraulische last _____ 6,5 m/h
- Uitschakelvermogen van MES d=2,5 _____ 47 microns

